

# Installation Note

---

## **Agilent Technologies E4407B Spectrum Analyzers and E7405A EMC Analyzers Low Frequency Extension (Option UKB) Retrofit Kit**



**Agilent Technologies**

Part Number E4407-90030 Supersedes: E4407-90007  
Printed in USA April 2003



E4407-90030

**Notice.**

The information contained in this document is subject to change without notice.

Agilent Technologies makes no warranty of any kind with regard to this material, including but not limited to, the implied warranties of merchantability and fitness for a particular purpose. Agilent Technologies shall not be liable for errors contained herein or for incidental or consequential damages in connection with the furnishing, performance, or use of this material.

Microsoft® is a U.S. registered trademark of Microsoft Corp.

---

## Introduction

This procedure can be used to retrofit the 100 Hz Low Frequency Extension (Option UKB) into an E4407B Spectrum Analyzer or E7405A EMC Analyzer.

Products Affected: .....	E4407B E4705A
Serial Numbers: .....	US40240000/US99999999 MY00000000/MY99999999
Options: .....	UKB
To Be Performed By: .....	<input checked="" type="checkbox"/> Agilent Technologies Service Center <input checked="" type="checkbox"/> Personnel Qualified by Agilent <input type="checkbox"/> Customer
Estimated Installation Time: .....	3.0 Hours
Estimated Verification Time: .....	4.0 Hours

## Installation Kit Parts List

Item	Description	Part Number
1	Input Attenuator, 5 Section (A8A5)	33321-60061
2	Cable Assembly, Filtered Low Band RF Input (W35)	E4404-20026
3	Cable Assembly, Attenuator to RYTHM (W17)	E4404-20014
4	Cable Assembly, RF Input (W6) (Non-Option BAB)	E4404-20009
5	Cable Assembly, RF Input (W6) (Option BAB)	E4407-20004
6	Cable Assembly, Atten & 2nd Conv Power & Control (W5)	E4404-60004
7	Connector Label, Opt UKB (A1MP21) (non-Option AYZ)	E4407-80007
8	Connector Label Opt UKB/AYZ (A1MP21) (Option AYZ)	E4407-80008 <sup>a</sup>
9	Nameplate, E7405A Opt UKB (A1MP16)	E7405-80002 <sup>b</sup>
10	Nameplate, E4407B Opt UKB (A1MP16)	E4407-80006 <sup>a</sup>
11	Option UKB Installation Note	this note
12	License Key Certificate	5964-5136 <sup>c</sup>
13	Letter	5964-5139 <sup>c</sup>

a. Unique parts for ESA spectrum analyzers upgrades.

b. Unique parts for EMC analyzers upgrades.

c. This part cannot be ordered. The part number is given only to identify the item in this kit.

---

### NOTE

After the hardware modifications have been made and Option UKB has been activated, you must adjust the frequency response of the analyzer. ESA/EMC Performance Verification and Adjustment Software is required to perform this adjustment, but is not included in this kit. The Performance Verification and Adjustment Software may be obtained by ordering the Service documentation and Software (Option 0BW).

---

## Tools Required

- T-10 TORX screwdriver
- T-15 TORX screwdriver
- Flat-blade screwdriver
- Sharp knife or razor blade
- Function Generator
- Synthesized Sweeper (26.5 GHz or higher)
- Digital Voltmeter
- Power Meter, Dual-Channel
- Microwave Power Sensor
- RF Power Sensor (2 required)
- 50  $\Omega$  Termination
- Power Splitter
- 20 dB Attenuator (Option 1DS only)
- APC 3.5 (m) Cable Assembly
- APC 3.5 (m) to Type N (m) Adapter
- APC 3.5 (m) to Type N (f) Adapter
- BNC Tee (f, m, f)
- Dual Banana to BNC (f) Adapter
- Adjustment Software

The Performance Verification and Adjustment Software may be obtained by ordering the Service documentation and software (Option 0BW).

## Torque Settings

To avoid potential RFI leakage and prevent connector damage, tighten screws and RF coax cable connectors to the following torque limits:

Item	Torque in Inch-Pounds
SMA Connector	8.5
SMC Connector	5.5
3.5-mm, T-10 TORX screws	14
4-mm, T-15 TORX screws	21
Pozidrive Screws	14

---

## Procedure

### Verify A8A1 3 GHz RF Assembly Part Number

1. Turn on the analyzer and wait for the initial adjustments to complete.
2. Press **System, More, Show Hdw.** This displays the Show Hardware screen, which lists the part number and serial number of most of the installed board assemblies.
3. Locate the part number of the “50Ω 3 GHz Input” assembly.
4. If the part number of the 50Ω 3 GHz Input assembly is E4403-60033 or lower, the A8A1 3 GHz RF assembly must be replaced. If the analyzer does not have the High Stability Frequency Reference, Option 1D5, order E4403-60073. If the analyzer does have Option 1D5, order E4403-60074.

---

**WARNING** Before you disassemble the instrument, turn the power switch OFF and unplug the instrument. Failure to unplug the instrument can result in personal injury.

---

---

**CAUTION** Electrostatic discharge (ESD) can damage or destroy electronic components. All work on electronic assemblies should be performed at a static-safe workstation. Refer to the documentation that pertains to your instrument for information about static-safe workstations and ordering static-safe accessories.

---

## Dress Cover Removal

1. Refer to [Figure 1](#) and disconnect the analyzer from ac power (1).
2. Remove any adapters or cables (2) connected to the front frame.
3. Carefully place the analyzer on the work surface with the front frame (3) facing down.
4. Position the handle (4) as shown.
5. Remove the four screws (5) that hold the rear frame and dress cover in place.
6. Remove the rear frame (6).
7. Pull the dress cover (7) off towards the rear of the analyzer.

**Figure 1** Dress Cover and Rear Frame Removal

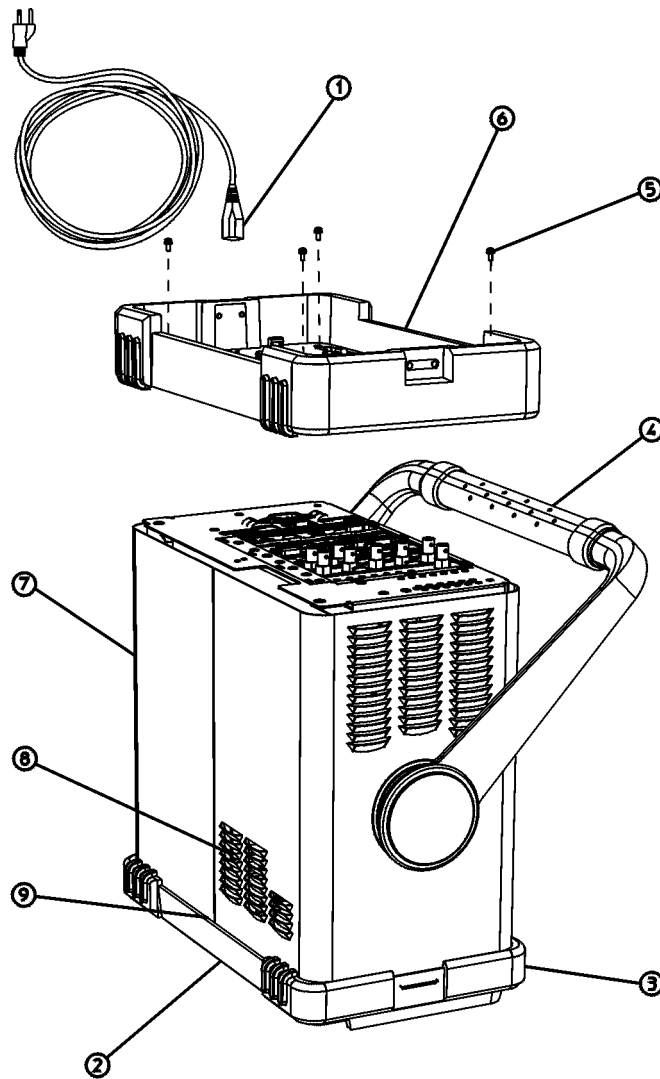

s745b

## Chassis Cover Removal

1. Refer to [Figure 2](#) and lay the analyzer flat.
2. Remove the 15 screws (2) and (3) attaching the chassis cover to the chassis. Note that the number of screws attaching the chassis cover may vary depending upon which options are installed.
3. Remove the chassis cover (1) from the chassis.

Figure 2 Chassis Cover Removal

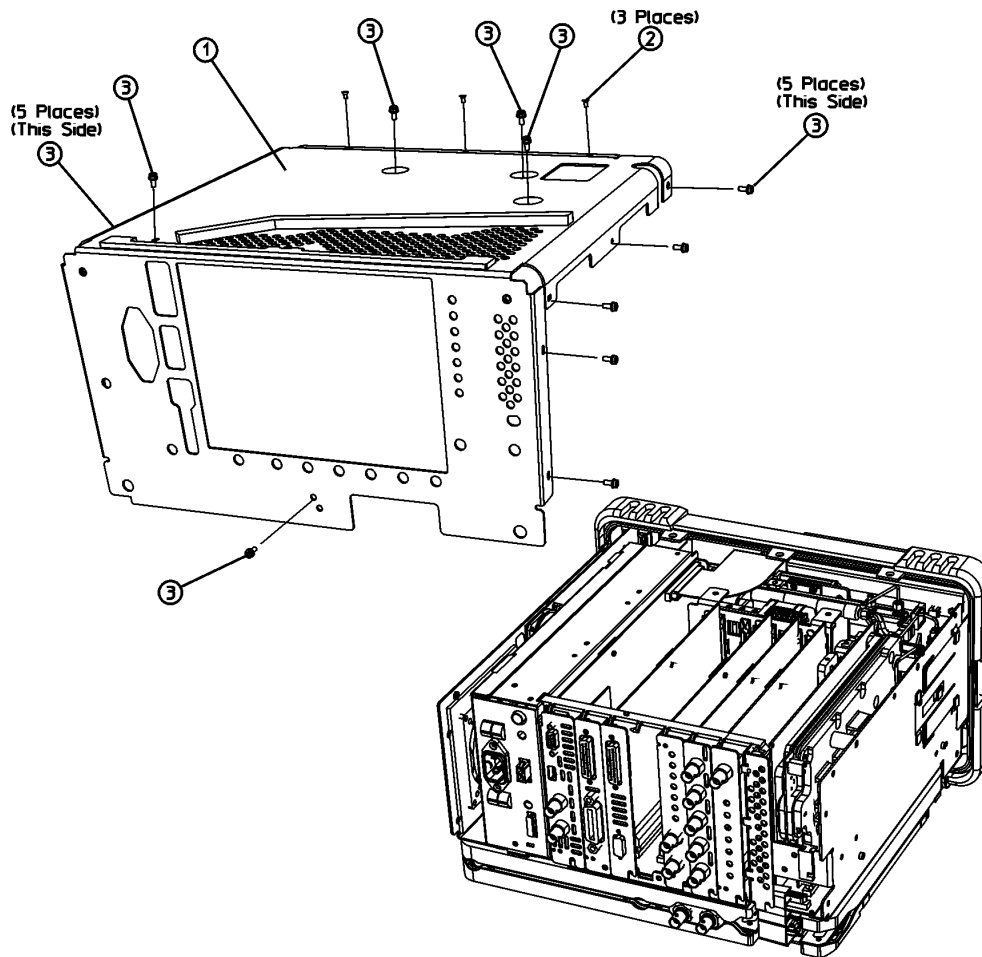

dl72b



## A1 Front Frame Assembly

---

**CAUTION** Use ESD precautions when performing this replacement procedure.

---

The A1 front frame assembly can be extended from the instrument without detaching any connections.

1. Refer to [Figure 3](#). Remove the two screws (1), on the bottom side of the instrument that secure the front frame to the RF assembly.

**Figure 3** A1 Front Frame Assembly Removal

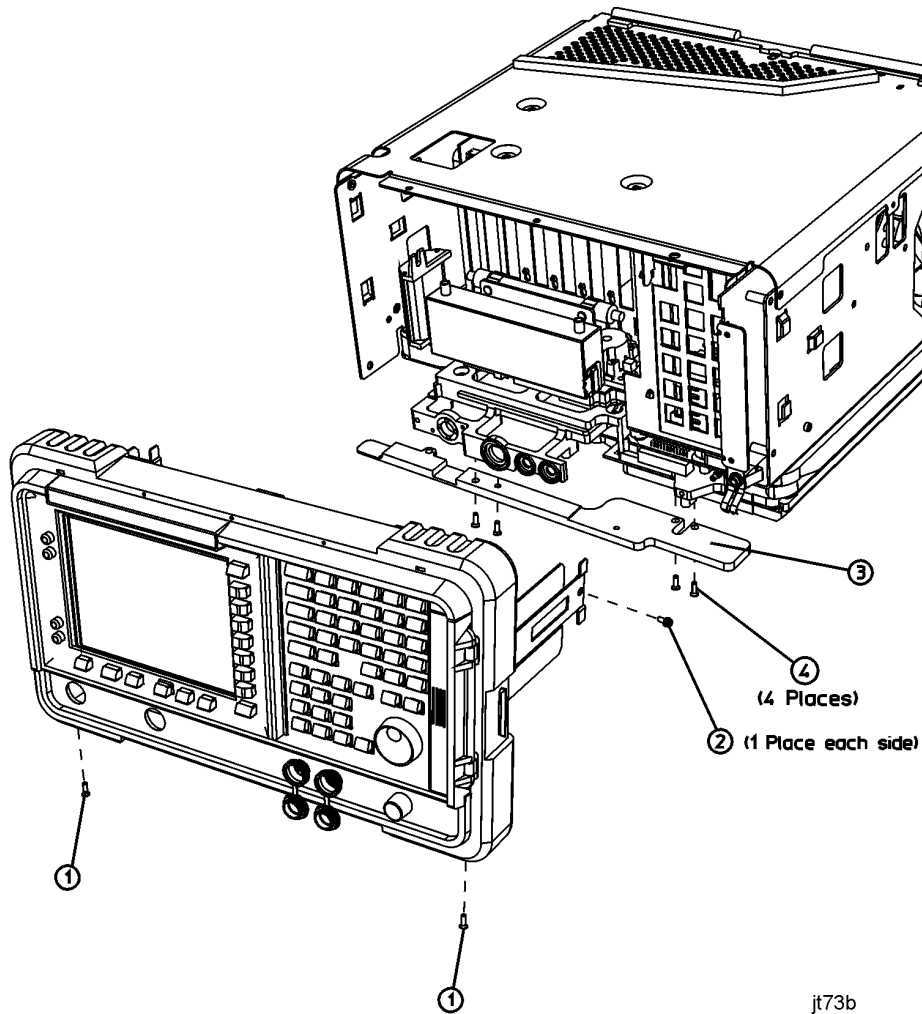

2. Place the instrument with the top side facing up and remove the remaining two screws (2) that secure the front frame subpanel to the chassis.
3. Slide the front frame forward until it catches on the tabs on the sides of the chassis.
4. Refer to [Figure 4](#). Disconnect the ribbon cable (1) from the A1A1 front panel interface board. Analyzers with Option B7B will have a second ribbon cable connecting to A1A1. Disconnect the second ribbon cable if present.

**Figure 4**

**Front Frame Ribbon Cable**

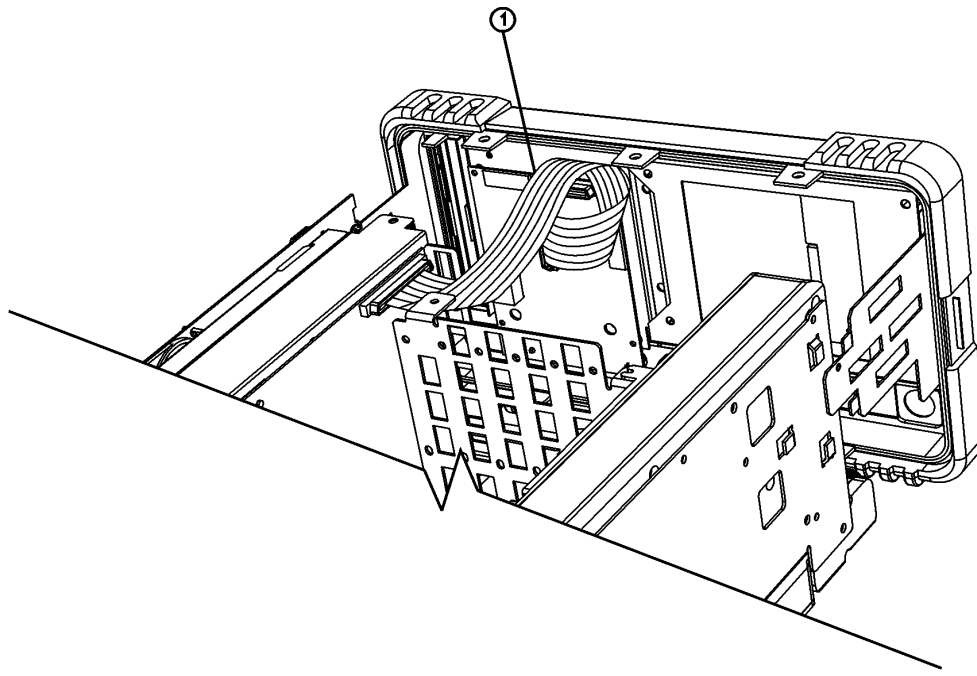

sl749b

5. Carefully pull the sides of the front frame subpanel away from the chassis and over the tabs on the chassis.
6. Slide the front frame forward to disengage from the chassis assembly.

## A1A1 Front Panel Interface Board Removal

1. Refer to [Figure 5](#). Remove the disk drive door (1).
2. Remove the RPG knob (2).
3. Remove the volume knob (3).

---

**TIP** You may need to exert considerable force in order to remove the RPG knob. It may be necessary to pry it off using a screwdriver as shown in [Figure 5](#).

---

**Figure 5** Removing the Front Frame Knobs

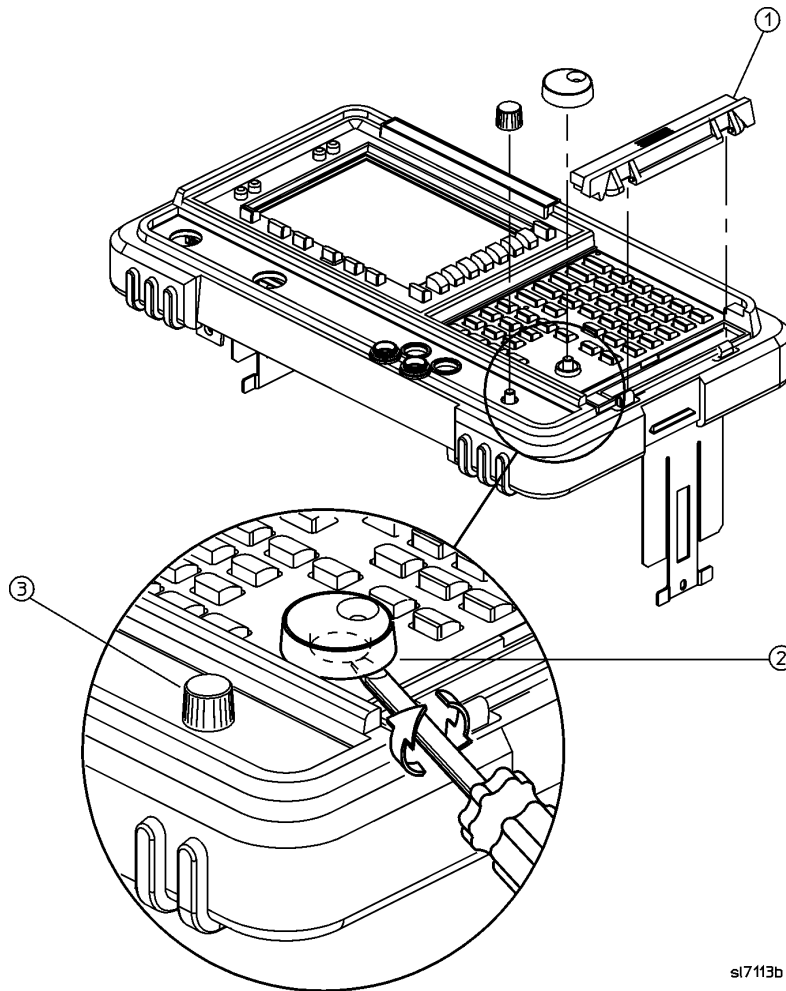

sl7113b

4. Refer to [Figure 6](#). Disconnect the two 2-wire backlight cables (1) from the front panel interface inverter board.
5. Disconnect W3 ribbon cable (2) from the front panel interface board.

---

**CAUTION** The W3 display ribbon cable connector (2) is delicate. With a small screwdriver or similar tool, gently push the lock tabs out from the back of the connector. Excessive force on the locking tab can break the retaining clips, and if broken, board replacement will be necessary.

---

**Figure 6** Disconnecting the Front Frame Wiring Connections

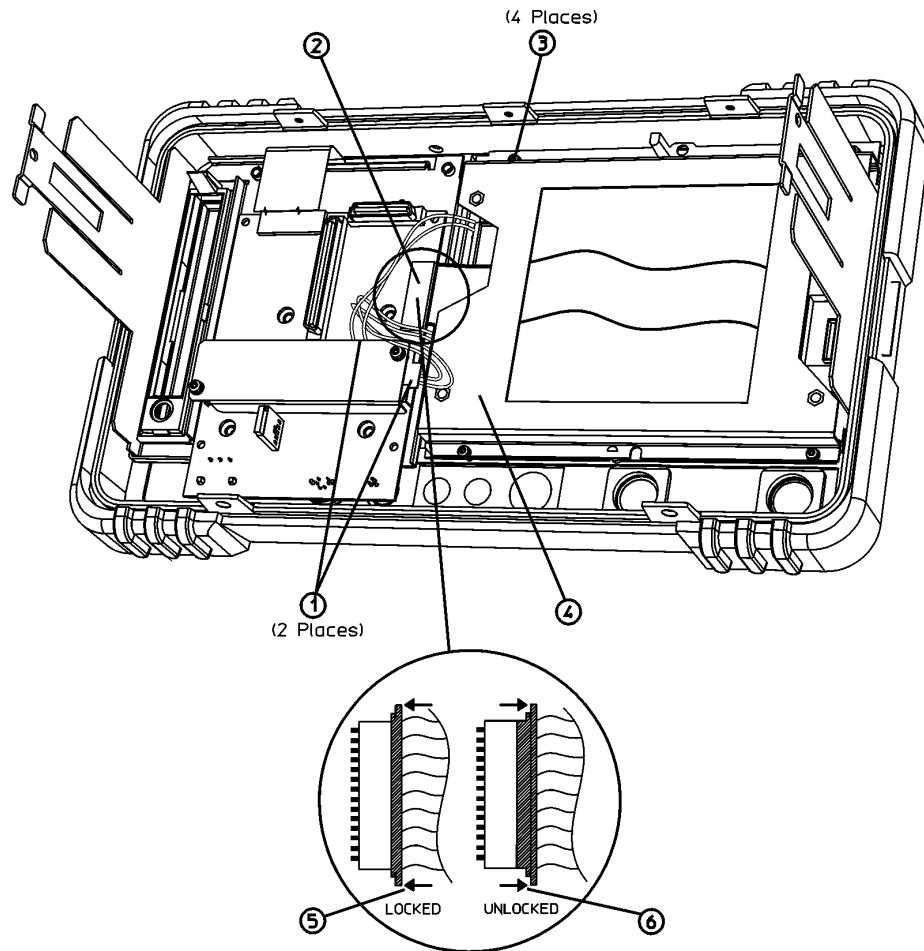

sl748b

6. Refer to [Figure 7](#). Remove the four screws (10) that secure the A1A1 front panel interface board (11) to the front frame.
7. Remove the front panel interface board from the front frame assembly.

---

**NOTE** There is a water-seal gasket placed around the volume control shaft that will need to be repositioned during the replacement procedure.

---

**Figure 7** Front Frame Assembly Parts

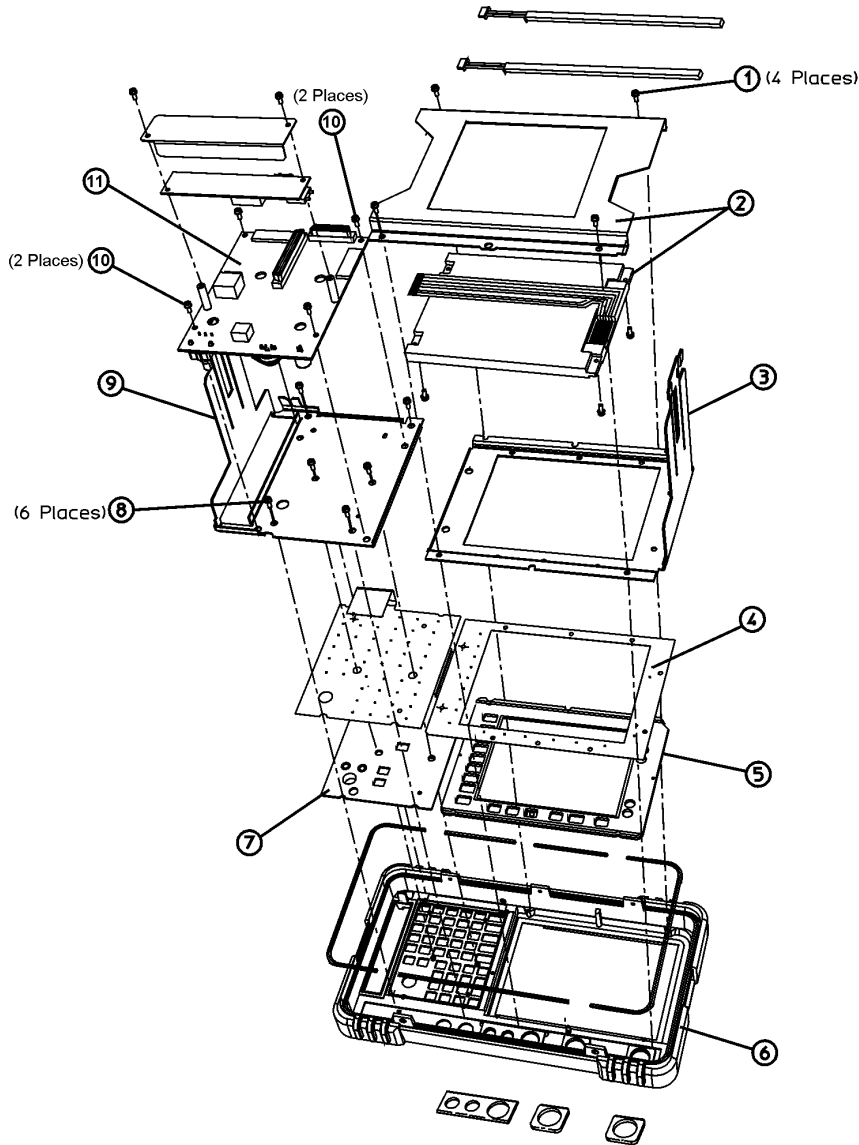

jl73a

## Attach Nameplate to Front Frame

1. Locate the nameplate in the kit. The nameplate is labelled with the analyzer product number (for example, "E4407B") and the frequency range of the analyzer.
2. Refer to [Figure 8](#) and remove the existing nameplate (1).
3. Clean the surface (2) of any adhesive residue.
4. Peel the backing (3) off the new nameplate and place it (4) as shown.

**Figure 8** Nameplate Replacement

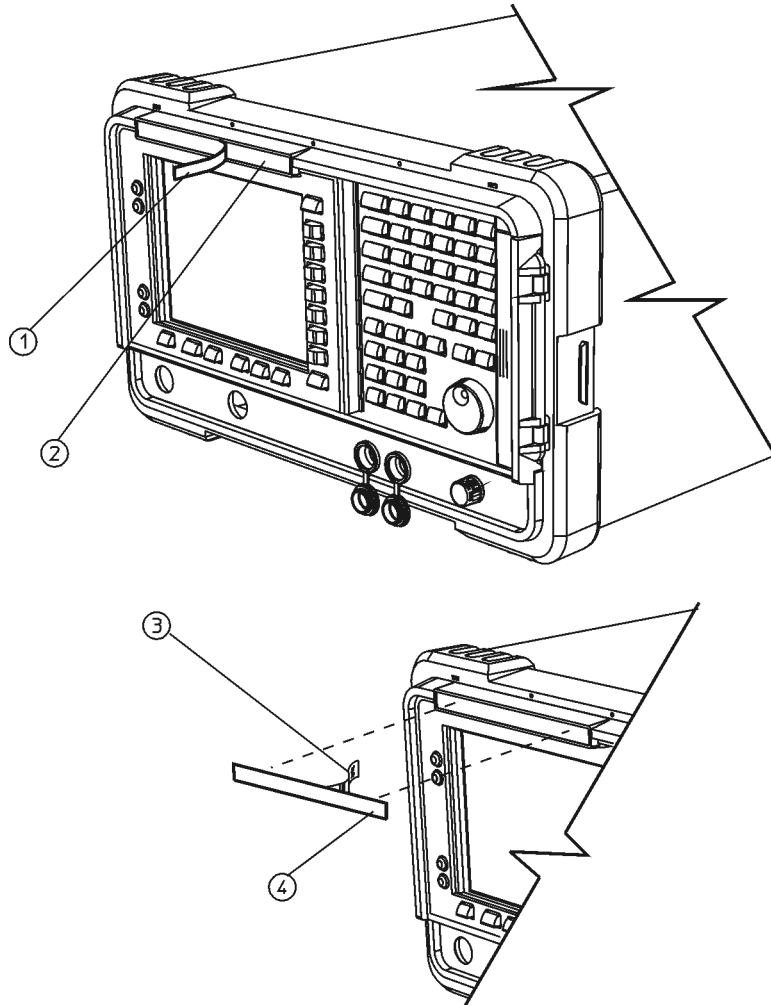

sl7114b

## Attach Connector Label and Connector Covers to Front Frame

1. Locate the connector label in the kit. The connector label has holes to accommodate the various front panel. The kit for the E4407B contains two connector labels. One is for use on analyzers without Option AYZ, External Mixing, and one is for use on analyzers with Option AYZ. Choose the connector label that is appropriate for the analyzer being modified.
2. Refer to [Figure 9](#). If the analyzer does not have a tracking generator, remove the hole plug for the RF OUT connector.
3. Remove the two connector covers from the front panel by pinching them from the sides and removing them (4) through the front of the front frame assembly.

**Figure 9** Connector Covers

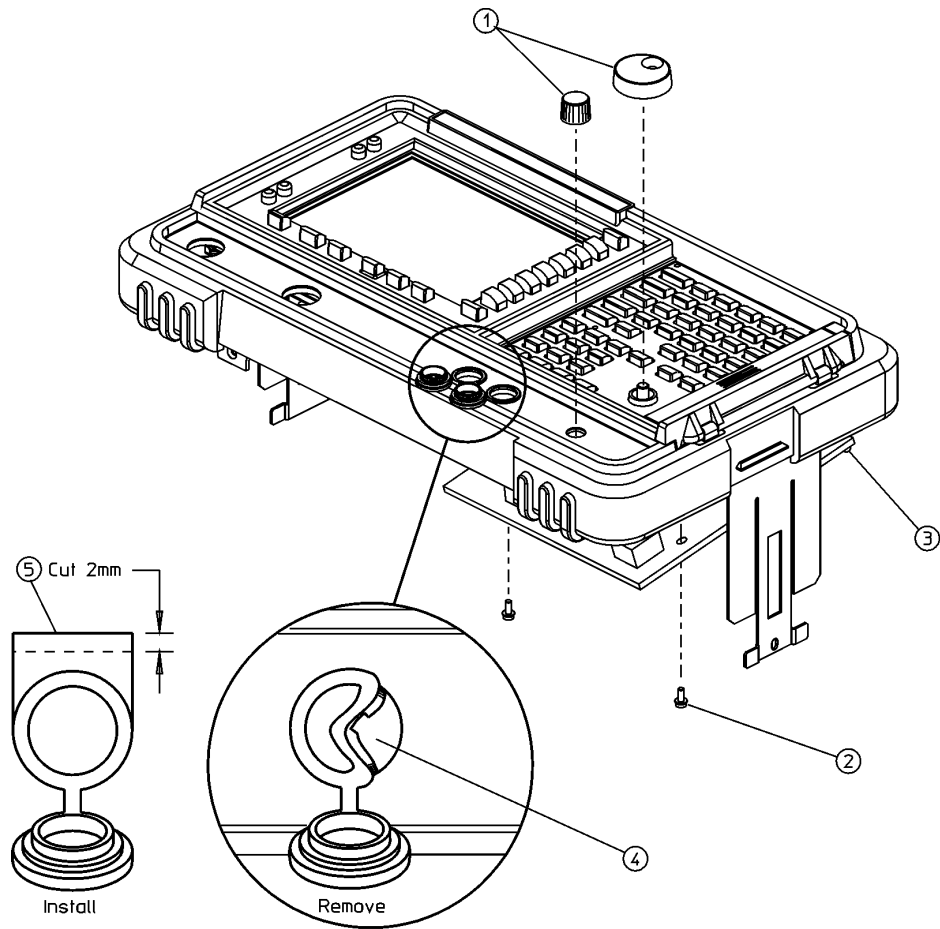

sl7111b

4. Refer to [Figure 10](#).
5. Peel off the old connector label loosening any residual adhesive with a sharp knife or razor blade as you go.
6. Before installing the new connector label, make sure the surface is free of any adhesive residue left from the old label. Failure to do so may result in an uneven (lumpy) appearance of the new label.

**Figure 10**                      **Connector Label Installation**

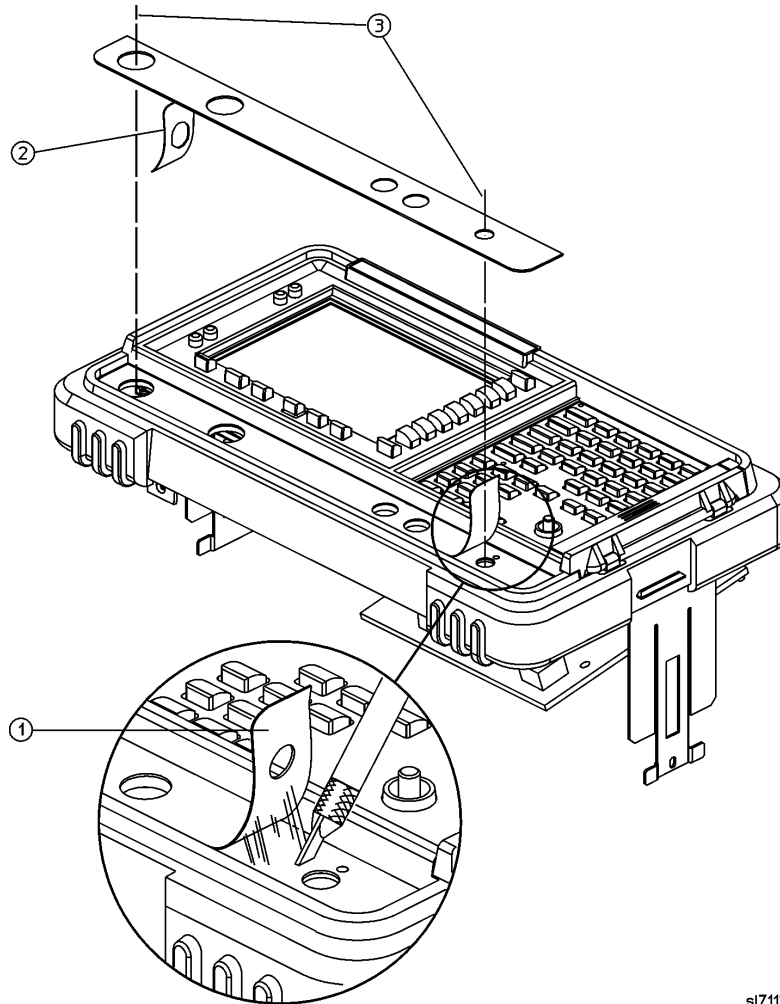

sl7112b

7. Peel the backing (2) off the new label, as shown.
8. Align and install the label by placing a finger in the RF OUT and VOLUME holes (3). Observe the alignment of the INPUT and PROBE POWER holes.
9. Refer to [Figure 9](#). Reinstall the two connector covers from the front panel by pinching them from the sides and installing them through the front of the assembly.

---

**TIP**                      It may be helpful to trim off approximately 2 mm of the tabs (5) on the connector covers prior to reinstalling them. This will help in aligning the covers.

---



10. Align the connector covers so they open downward.
11. Reinstall the hole plug that was removed if your analyzer does not have a tracking generator.

### Remove the 3.0 GHz RF Assembly

1. Refer to [Figure 11](#). Disconnect the SMB cable (1) from the IF assembly.
2. Disconnect the RF assembly ribbon cable (2).

Figure 11 Disconnect the RF Assembly Ribbon Cable

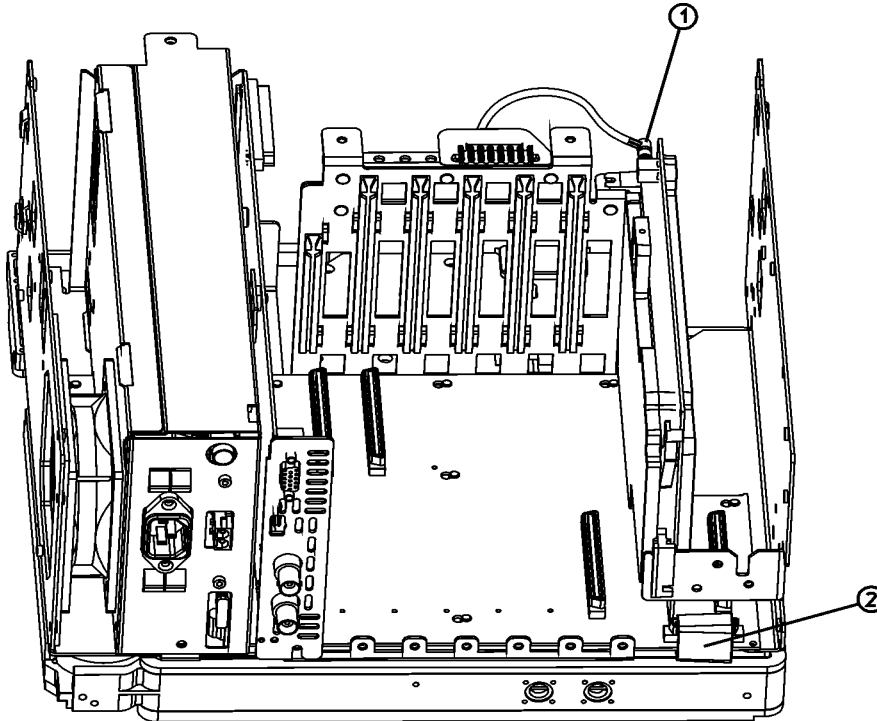

s1771b

3. Refer to [Figure 12](#). If the analyzer has a tracking generator, disconnect the cable (3) from the tracking generator connector. Tuck the cable end with the yellow tag away behind the microcircuits (4) of the RF assembly.

**Figure 12**                      **Disconnect the Tracking Generator Cables**

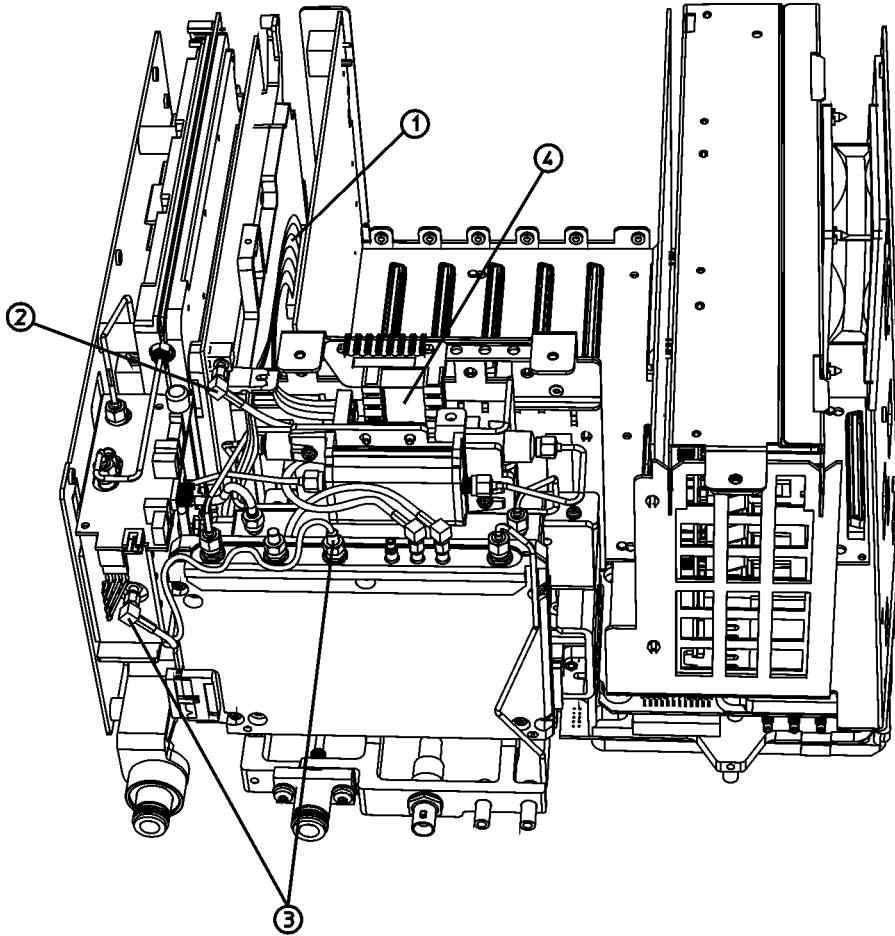

sl773b

4. Refer to [Figure 13](#). Put the analyzer upside down and remove the six screws (1) marked “RF Deck” securing the RF assembly to the chassis.
5. Carefully lift the RF assembly from the chassis.

---

**CAUTION** The cables and assemblies are easily damaged. Once removed, it is best to lay the RF assembly flat on a work surface. Do not rest it against any of the microcircuits or cables.

---

**Figure 13** Remove the RF Deck Screws

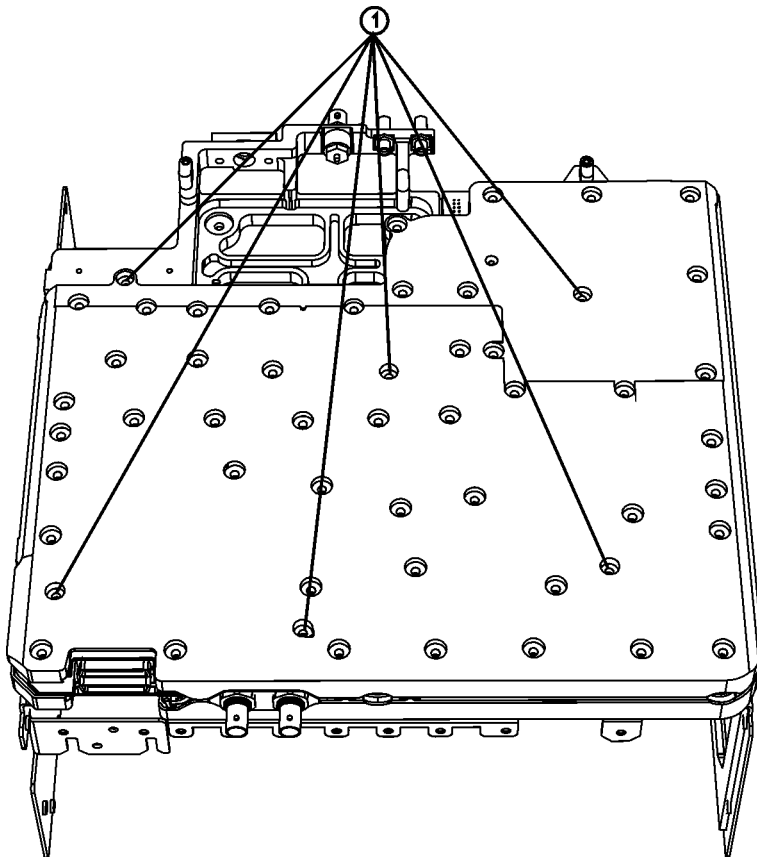

sl779b

## Disassemble Microwave RF Assembly

1. Refer to [Figure 14](#). Disconnect the two ends of ribbon cable W16 (3) which connect to the A8A6 YIG-Tuned Filter/Mixer (“RYTHM”) and the LO Amplifier/ IF Switch (“LOIS”).

**Figure 14**                      **Disconnect the RYTHM and LOIS Ribbon Cables**

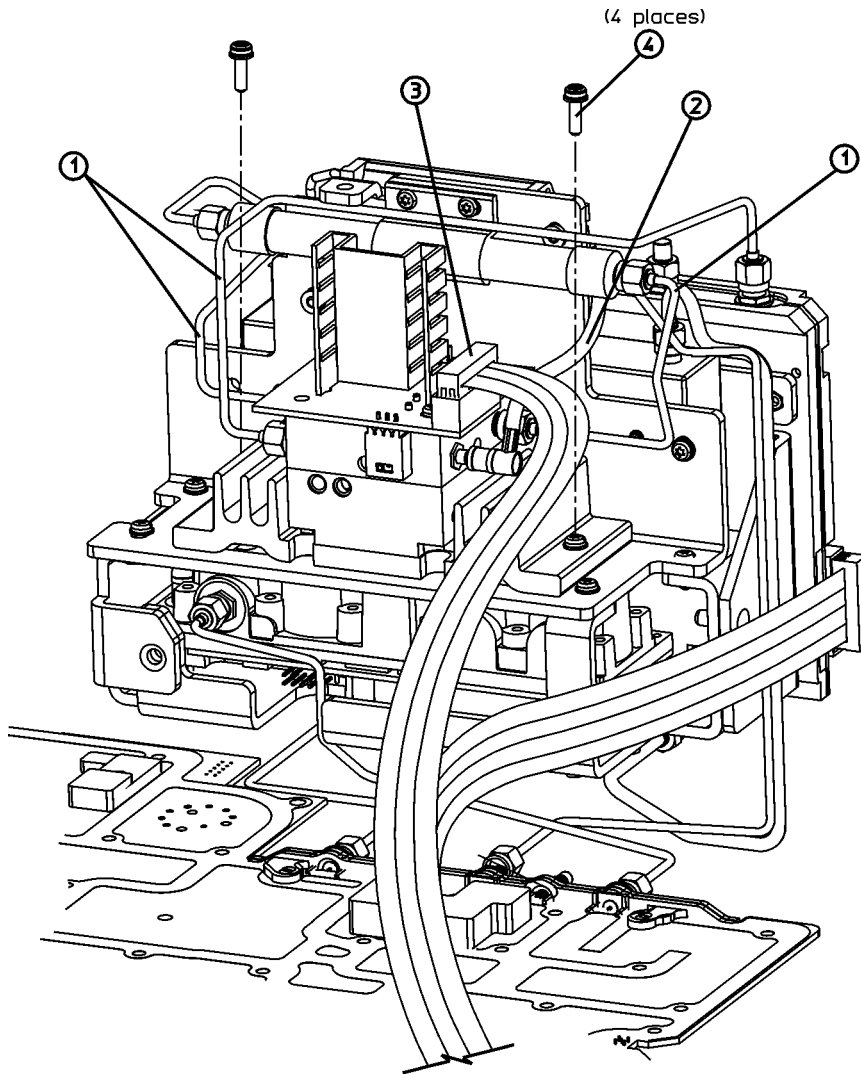

sl774b

Figure 15

Disassemble Microwave RF Assembly

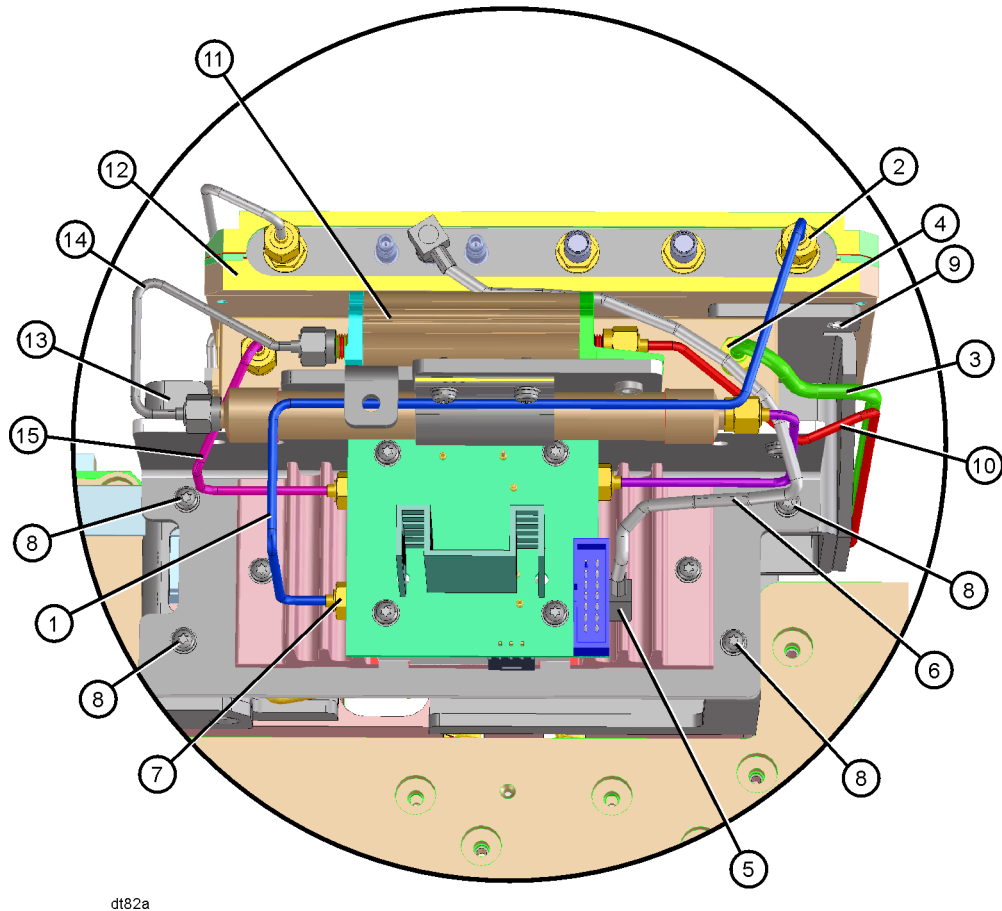

dt82a

2. Refer to [Figure 15](#).
3. Disconnect semi-rigid coax W22 (1) from A8A6J4 (7) and A8A4J2 (2).
4. Disconnect flexible coax W20 (6) from A8A6J1 (5). Pull the free end of the cable toward the A8A4 LOIS.
5. Disconnect semi-rigid coax W6 (3) from J1 (4) of A8A5 Input Attenuator and the J1 Input Connector. W6 will not be reused.
6. Disconnect semi-rigid coax W8 (10) from the output of the A8A3 DC Block (11) and A8A1A2J2.
7. Disconnect the ribbon cable (13) connected to the A8A5 Input Attenuator.
8. Disconnect semi-rigid coax W19 (14) from the input of the A8A3 DC Block (11) to the A8FL1 Low Pass Filter. This cable will not be reused.
9. Remove the four screws (8) which secure the micro sub-bracket to the micro bracket. These screws will be used for later reassembly.
10. Lift the micro sub-bracket, with A8A3 DC Block, A8FL1 Low Pass Filter, A8A4 RYTHM, and A8A5 Input Attenuator attached from the micro bracket.
11. Remove the A8A3 DC Block (11) by removing the two screws securing A8A3 to the micro sub-bracket. These screws and A8A3 will not be reused.

12. Remove semi-rigid coax W17 (15) between A8A5 Input Attenuator and A8A6 RYTHM. This cable will not be reused.
13. Remove the A8A5 Input Attenuator by removing the two screws securing A8A5 to the micro sub-bracket. The screws will be used for later reassembly, but the original A8A5 will not be reused.
14. Refer to [Figure 16](#). Disconnect ribbon cable W5 (1) from the A8A2 Second Converter and A8A1 3.0 GHz RF Assembly. This cable will not be reused.

**Figure 16**                      **Second Converter Ribbon Cable**

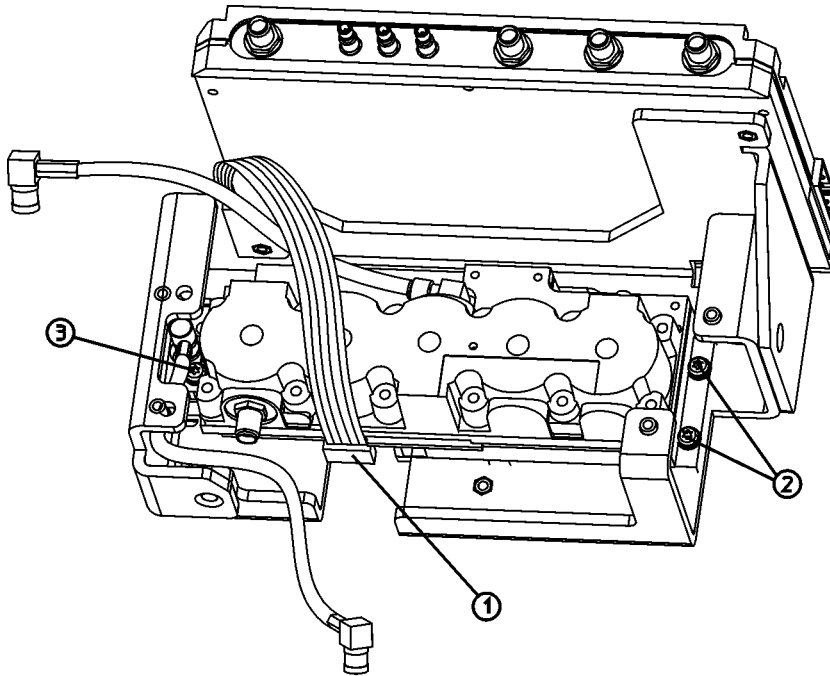

sl778b

## Assemble Option UKB Microwave RF Assembly

1. Refer to [Figure 16](#). Locate the new W5 ribbon cable in the kit. This cable has a 24-pin connector on one end, and 14 pin and 10 pin connectors on the other ends. Connect the 24-pin connector to A8A1A1J2. Connect the 10-pin connector to the A8A2 Second Converter. Leave the 14-pin connector end free and route in front of the A8A4 LOIS.
2. Locate the new A8A5 Input Attenuator in the kit. Install the new A8A5 to the micro sub-bracket using the two screws removed earlier. The SMA connectors on A8A5 should face upward, toward A8FL1 Low Pass Filter.
3. Refer to [Figure 17](#). Locate the new semi-rigid coax W17 in the kit. Connect W17 (2) between A8A5J2 and A8A6J3. Torque the connectors to 10 inch-pounds.

Figure 17 Assemble Option UKB Microwave RF Assembly

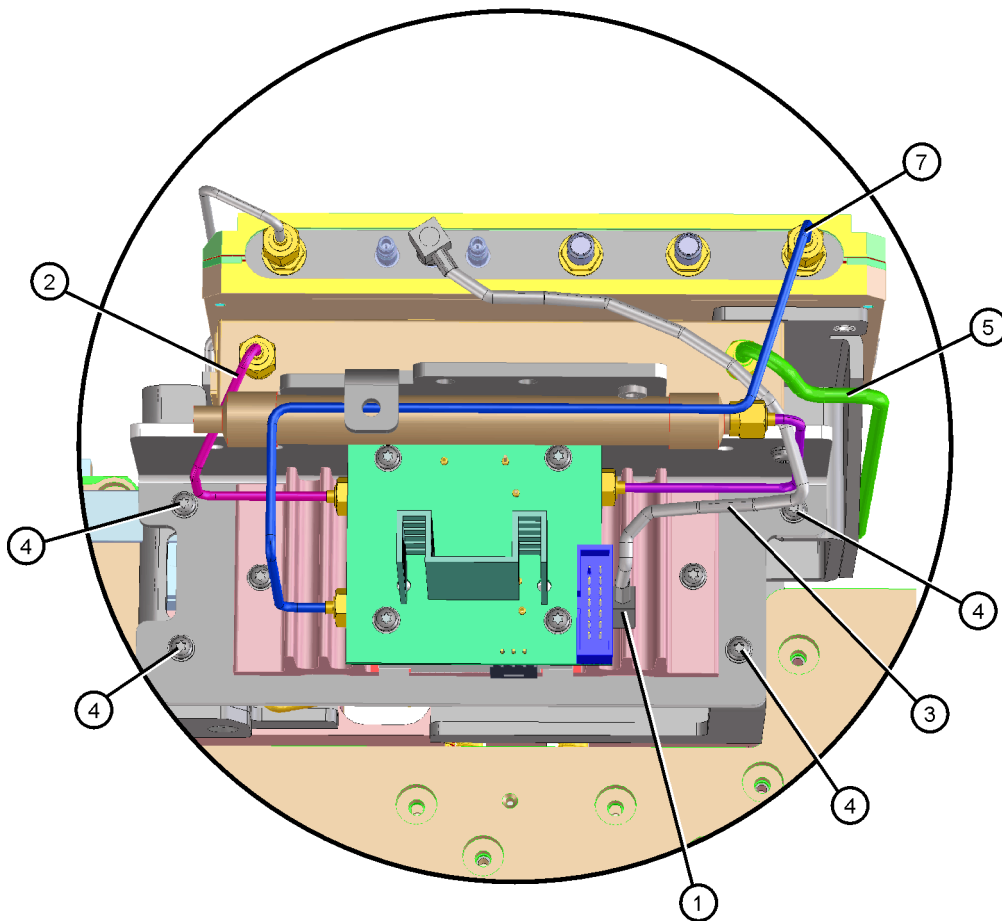

dt81a

4. Re-install the micro sub-bracket onto the micro bracket. Secure the sub-bracket to the bracket using the four screws (4) removed earlier.
5. Connect the 14-pin connector of ribbon cable W5 to the A8A5 Input Attenuator.

Figure 18

Option UKB Microwave RF Assembly Front View

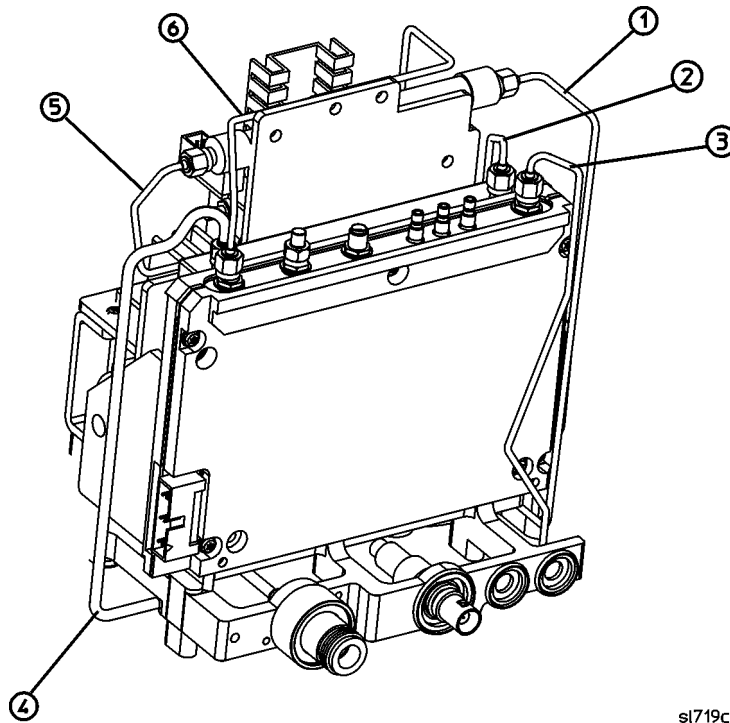

sl719c

6. Refer to [Figure 18](#). Locate the new semi-rigid coax W35 in the kit. Connect W35 (1) between the output of A8FL1 and A8A1A2J2. Torque the connectors to 10 inch-pounds.
7. Locate the two semi-rigid coax cables W6 (4) in the kit. Part number E4404-20009 should be used if the analyzer has a Type N input connector and part number E4407-20004 should be used if the analyzer has an APC 3.5 mm connector (Option BAB). Select the appropriate cable and connect between A8A5J1 and the J1 Input Connector. Torque the connectors to 10 inch-pounds.
8. Refer to [Figure 17](#). Re-install semi-rigid coax W22 (7) from A8A6J4 to A8A4J2. Torque the connectors to 10 inch-pounds.
9. Refer to [Figure 17](#). Route the loose end of flexible coax W20 (3) underneath A8FL1 and connect to A8A6J1 (1).



Figure 19

Connect RYTHM and LOIS Ribbon Cable

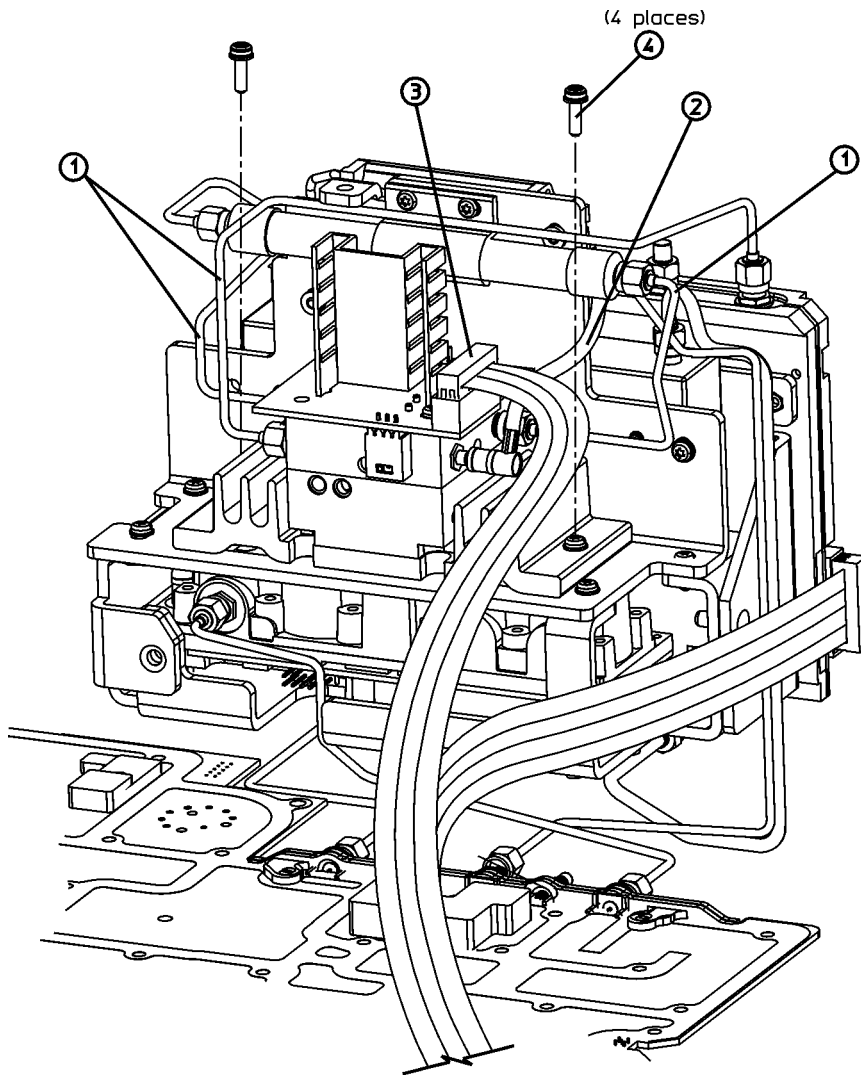

sl774b

10. Refer to [Figure 19](#). Locate ribbon cable W16 (3) that was removed earlier. The cable has a 30-pin connector, a 14-pin connector, and a 16-pin connector. Connect the 14-pin connector to A8A4 LOIS and the 16-pin connector to A8A6 RYTHM. Tuck the free end of the ribbon cable between the A8A6 RYTHM and A8FL1.

## Replace A8 3.0 GHz RF Assembly

1. Position the analyzer upside down on the work surface.
2. Refer to [Figure 21](#). Tuck the cables away behind the microcircuits (4).
3. Refer to [Figure 20](#). Lower the RF assembly onto the chassis taking care not to pinch any cables.

Figure 20            Replace RF Assembly

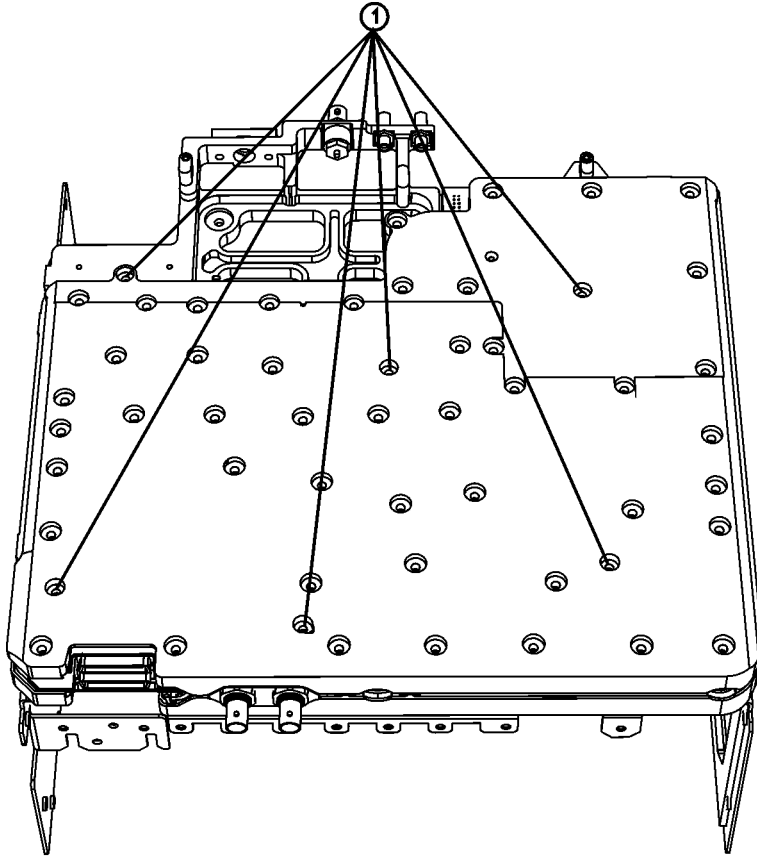

sl779b

4. Refer to [Figure 20](#). Replace the six screws (1) securing the RF assembly to the chassis, and tighten them to 9 inch-pounds.
5. Refer to [Figure 21](#). Connect the SMB cable (2) to the IF assembly.
6. If the analyzer has a tracking generator, reconnect the cables (3) to it, and tighten the SMA connector to 10 inch-pounds.

**Figure 21**                      **Reconnect Cables**

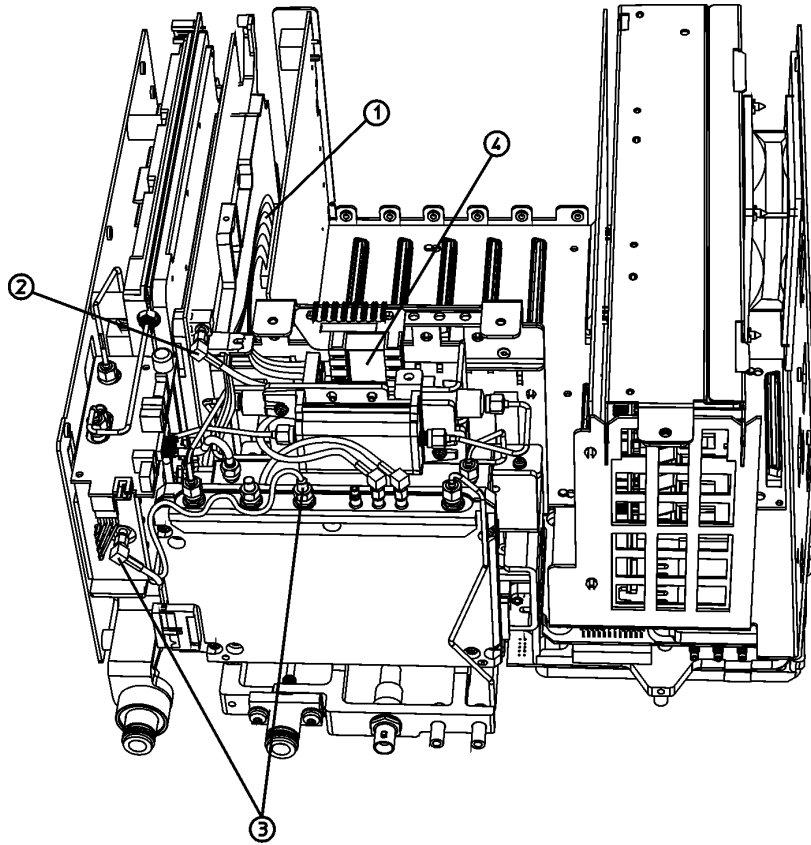

sl773b

7. Refer to [Figure 22](#). Connect the RF assembly ribbon cable (2).

**Figure 22**                      **Connect the RF Assembly Ribbon Cable**

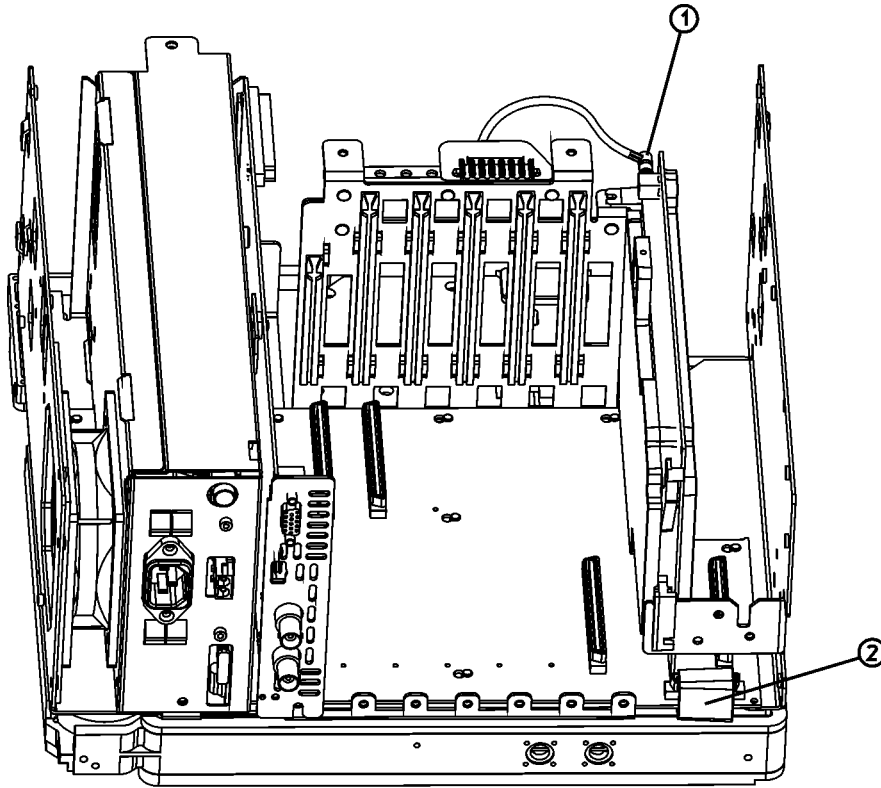

st771b

## Replace A1A1 Front Panel Interface Board

1. Refer to [Figure 7](#). Place the front panel interface board (11) in the correct position in the front frame assembly. Make sure the water seal is in place around the volume control shaft.
2. Replace the four screws that secure the board to the front frame. Tighten them to 9 inch-pounds.
3. Refer to [Figure 6](#). Connect the W3 display ribbon cable (2) to the front panel interface board.

---

**TIP**

An easy way to insert this delicate cable into the connector is to place your finger on the cable, in the center of the LCD display, and gently slide the cable toward the connector until they align. Then, providing guidance with the other hand as necessary, slide the cable until the end slips into the connector.

Ensure the cable end is seated completely and is aligned straight within the connector body.

Continue to hold the cable in place with your finger, and with the other hand gently press the locking tabs (5) into place.

If you experience display problems, check this connection.

---

4. Reconnect the two 2-wire backlight cables (1) to the inverter board, making sure that the cables are dressed away from the openings for the control knobs.
5. Press the volume and RPG knobs onto their control shafts.

## Replace Front Frame Assembly

1. Align the A1 front frame subpanel rails with the chassis as shown in [Figure 23](#).

Figure 23 Front Frame Assembly Replacement

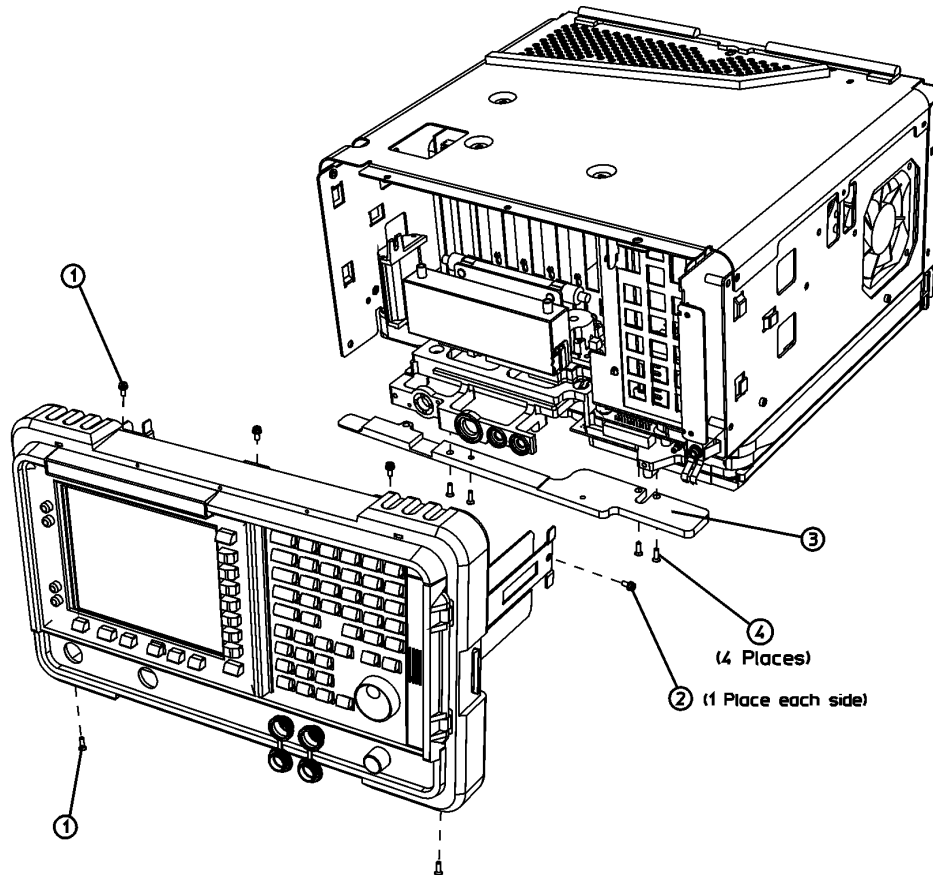

si7118b

2. Refer to [Figure 24](#). Connect the ribbon cable (1) to the front frame assembly. If Option B7B is installed, there will be two ribbon cables to connect.
3. Carefully slide the front frame toward the chassis, assuring the ribbon cable(s) are not pinched between assemblies, and the RF input connector lines up correctly with the opening in the front frame.

**Figure 24**                      **Front Frame Ribbon Cable**

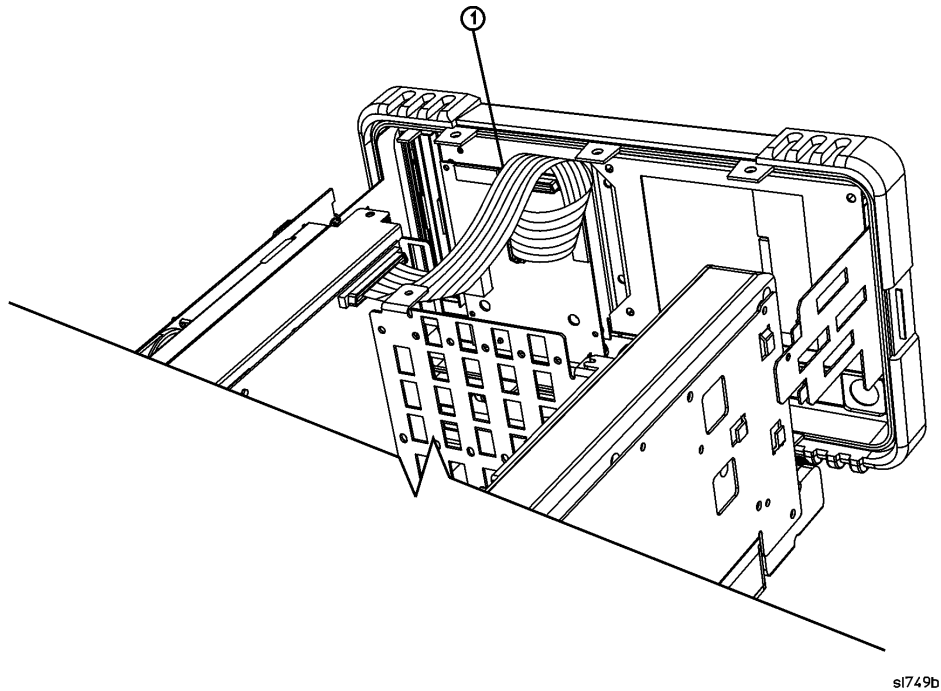

4. Refer to [Figure 23](#). Replace the screws that secure the front frame to the chassis (2) and to the RF assembly (1). Tighten them to 9 inch-pounds.

## Replace Chassis Cover

1. Carefully position the chassis cover (1) on the instrument as shown in [Figure 25](#), then lower onto the instrument.
2. Replace the 17 screws (2) and (3) as indicated on the instructions on the chassis cover. Tighten the screws to 9 inch-pounds.

Figure 25 Chassis Cover Replacement

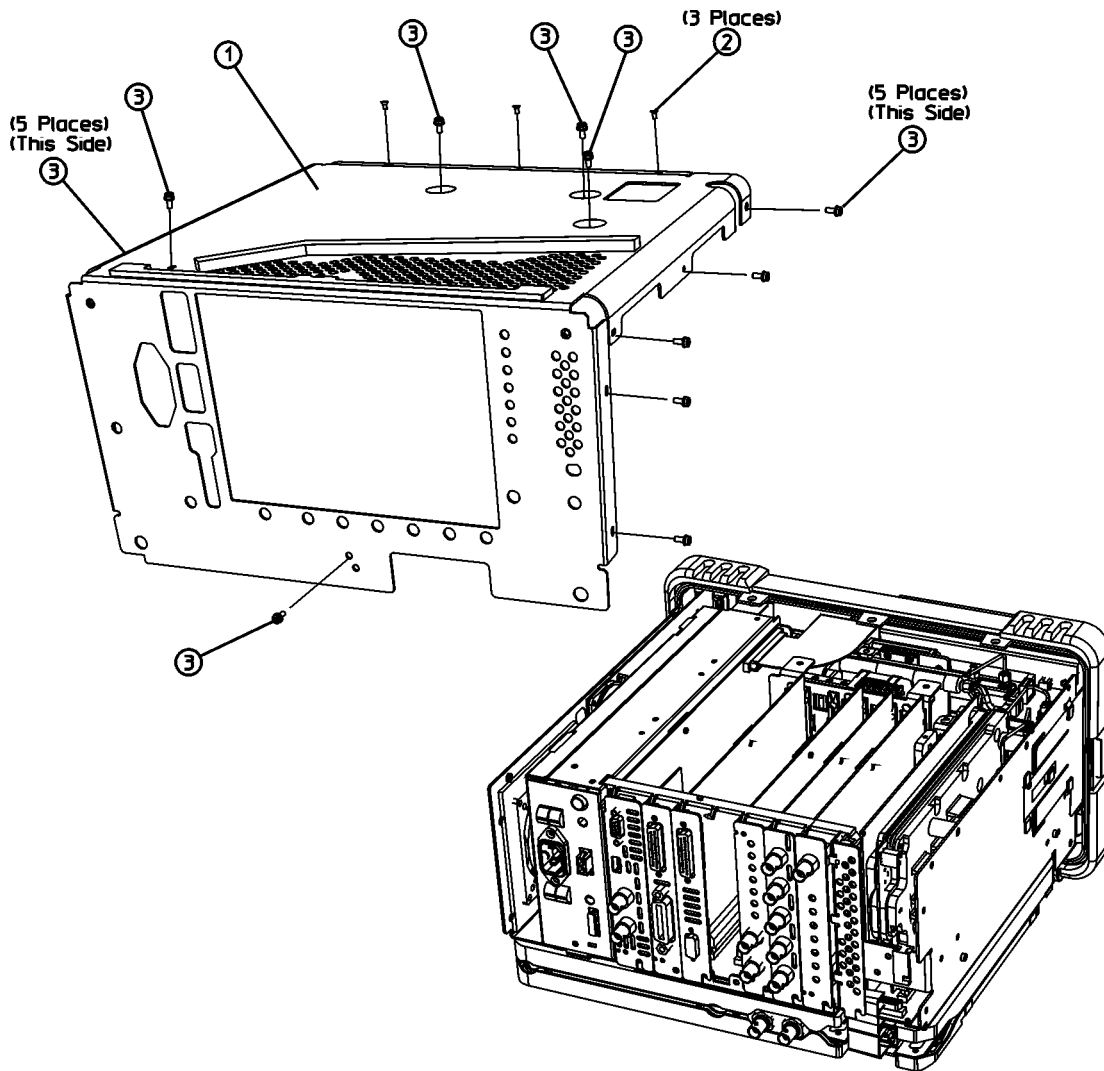

di72b



## Replace Dress Cover

1. Refer to [Figure 26](#). Carefully place the spectrum analyzer on the work surface with the front frame (3) facing down.
2. Replace the dress cover, matching the grill (8) on the bottom of the dress cover to the bottom of the analyzer.
3. Fit the leading edge of the dress cover completely into the slot (9) on the back of the front frame assembly.
4. Replace the rear frame assembly (6) using the four screws (5) to fasten the rear frame to the analyzer. Tighten them to 21 inch-pounds.

Figure 26 Dress Cover, Rear Frame Replacement

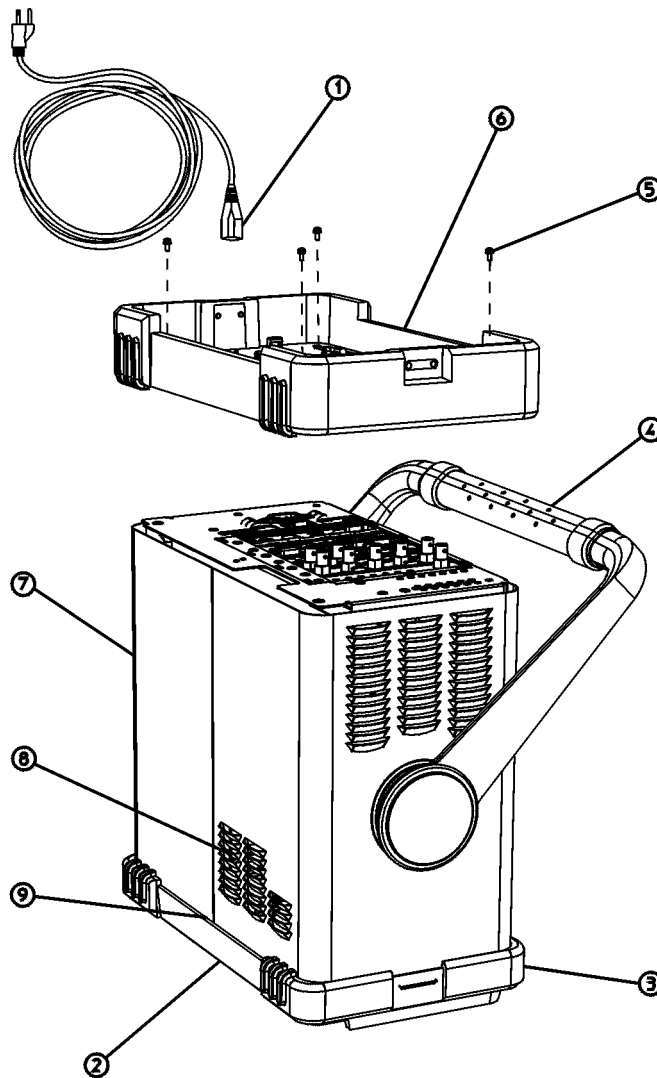

sl745b

## Firmware Revision Verification

1. Turn on the analyzer and wait for the power-on alignments to complete. Check that there are no error messages displayed.
2. Press **System, More, Show System**. Make a note of the firmware revision and see if Option B72, Expansion Memory, is listed on the display.
3. If the firmware revision is A.06.00 or later, the firmware does not need to be upgraded and you can skip steps 4 through 6.
4. If your firmware revision is prior to A.06.00, you must upgrade your analyzer firmware before the license key can be activated.
5. If Option B72, Expansion Memory is installed, you should upgrade the instrument firmware to the latest version using one of the following methods:
  - Download the instrument firmware via the world-wide web at [http://www.agilent.com/find/esa\\_firmware](http://www.agilent.com/find/esa_firmware). This entire process of upgrading firmware will take approximately 45 minutes.  
**Note:** If you are upgrading an EMC analyzer, look for the link stating “*EMC Firmware*” at this website.
  - Receive the latest firmware upgrade disk set by ordering upgrade Option UE2.  
**Note:** Special instructions in the Agilent ordering configurator should have made you aware of Option UE2 in case access to the internet wasn't available.
6. If Option B72, Expansion Memory is not installed, you should upgrade the instrument firmware to version A.07.05. This is the latest version for instruments that do not have Option B72 installed.
  - Download the instrument firmware via the world-wide web at [http://www.agilent.com/find/esa\\_firmware](http://www.agilent.com/find/esa_firmware). Look for the link stating “*ESA Firmware Version A.07.05*”. This entire process of upgrading firmware will take approximately 45 minutes.
  - Order upgrade Option B72, which includes the expansion memory and the latest ESA firmware upgrade disk set.

## Activate the Option UKB License Key

The license key supplied in this kit allows you to activate the 100 Hz Low Frequency Extension (Option UKB).

1. Press **System, More, More, Licensing, Option**. When you press **Option**, the alpha editor will be activated. For instructions on using the alpha editor, refer to the *Agilent Technologies ESA Spectrum Analyzers User's Guide*.
2. Use the alpha editor to enter the three-character designation for the option, in this case, "UKB", that you want to activate.
3. Press **Enter** when done.
4. Press **License Key**. When you press **License Key** the alpha editor will be activated.
5. Use the alpha editor and the numeric keypad to enter the 12-character license key number (for example: D7C374DABD5B) for the option that you want to activate.
6. Press **Enter** when done.
7. Press **Activate** to turn on the option.
8. If the option and license key entries were correct, a message stating "Option Activated" will appear on the analyzer display.

## Adjustments and Performance Verification

1. Verify that Option UKB was activated by pressing **System, More, Show System**. Verify that there is an entry which reads, "UKB: Low Freq. Extension".
2. Perform the Frequency Response Adjustment, located in the Adjustment Software.
3. Perform the following performance verification tests, located in the analyzer Calibration Guide:
  - Frequency Response
  - Displayed Average Noise Level
  - Residual Responses
4. If you have problems performing either of these tests, get in touch with the nearest Agilent Technologies sales and service office listed in the troubleshooting chapter of the analyzer User's Guide.